

# MB 1106

## NOTAS ESPECIAIS:

- Siga atentamente todas as instruções de montagem.
- Monte seu produto no local ou próximo de onde será colocado. Movimentações do produto já montado podem avariá-lo.
- Faça a montagem em uma superfície limpa e plana.
- Aconselhamos usar a própria embalagem de papelão para forrar o chão.
- Verifique se as quantidades de peças e acessórios estão de acordo com o manual de montagem.
- Compare atentamente os furos de cada peça com a ilustração do manual.
- Se o produto necessitar fixação na parede, tenha cuidado para não atingir fios e canos ao furar a parede.

Obs.: Caso necessite solicitar peças de reposição, por favor, utilize os códigos correspondentes.

## SPECIAL NOTES:

- Carefully follow all assembly instructions.
- Assemble your product at or near the location where it will be placed. Moving the assembled product may damage it.
- Perform the assembly on a clean and flat surface.
- We recommend using the cardboard packaging to cover the floor.
- Check that the quantities of parts and accessories match the assembly manual.
- Carefully compare the holes of each part with the illustration in the manual.
- If the product requires wall mounting, be careful not to hit electrical wires or pipes when drilling.

Note: If you need to request replacement parts, please use the corresponding codes.

## NOTAS ESPECIALES:



- Siga atentamente todas las instrucciones de montaje.
- Monte su producto en el lugar o cerca de donde será colocado. Mover el producto ya montado puede dañarlo.
- Realice el montaje en una superficie limpia y plana.
- Recomendamos usar el propio embalaje de cartón para cubrir el suelo.
- Verifique que las cantidades de piezas y accesorios coincidan con el manual de montaje.
- Compare cuidadosamente los orificios de cada pieza con la ilustración del manual.
- Si el producto requiere fijación a la pared, tenga cuidado de no perforar cables o tuberías.

Nota: Si necesita solicitar piezas de repuesto, por favor, utilice los códigos correspondientes.

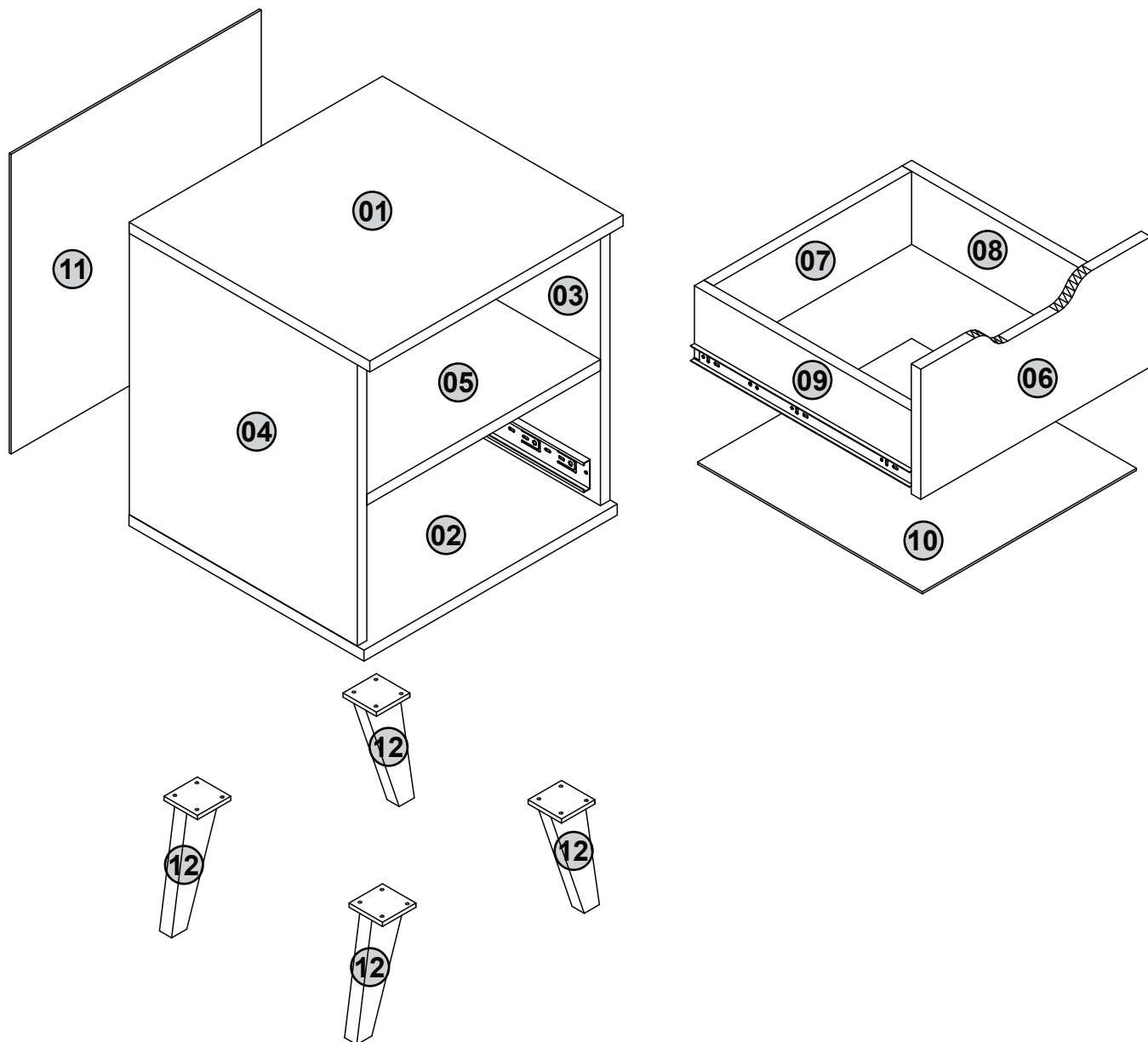
Item	Cod	Descrição   Descripción   Description			Dimensões Dimensiones   Dimensions mm			Qty
		Português	Español	English	Comp. Largo Length	Larg. Ancho Width	Esp. Grosor Thickness	
01	64231	Tampo	Tapa	Top	400	380	15	01
02	64777	Base	Base	Base	400	380	15	01
03	84764	Lateral Direita	Lateral Derecha	Right Panel	385	370	15	01
04	84763	Lateral Esquerda	Lateral Izquierda	Left Panel	385	370	15	01
05	84765	Prateleira	Estante	Shelf	369	369	15	01
06	84766	Frente Gaveta	Frente de Cajón	Drawer Front	363	178	15	01
07	60422	Costa Gaveta	Trasera del Cajón	Drawer Back	313	100	15	01
08	60087	Lateral Gav. Dir.	Lateral Der. del Caj.	Right Drawer Side	350	100	15	01
09	67214	Lateral Gav. Esq.	Lateral Izq. del Caj.	Left Drawer Side	350	100	15	01
10	60423	Base Gaveta	Fondo de Cajón	Drawer Bottom	355	338	03	01
11	60424	Costa	Panel Trasero	Back Panel	395	410	03	01
12	63151	Pés	Pie	Leg	170	55	20	04

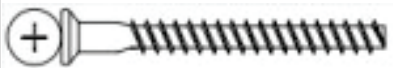
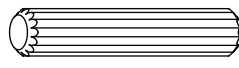
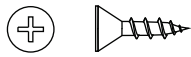
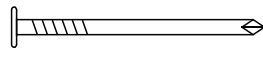
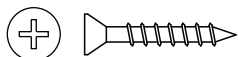
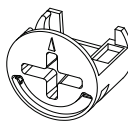
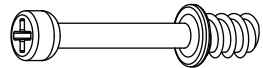
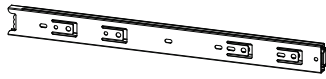

# Lista de materiais | Lista de materiales | Hardware list

<b>A</b>	 77070	Parafuso Estrutural Ø5x50	<b>12</b>	<b>B</b>	 67229	Cavilha Ø8x30	<b>08</b>
<b>C</b>	 1216	Parafuso Chata Ø3,5x14	<b>10</b>	<b>D</b>	 77072	Prego Ø10x10	<b>30</b>
<b>E</b>	 1451	Parafuso Chata Ø4x20	<b>16</b>	<b>F</b>	 66706	Tambor Minifix	<b>04</b>
<b>G</b>	 2239	Haste Minifix	<b>04</b>	<b>H</b>	 158	Corrediça Telescópica 350MM	<b>01</b>
<b>I</b>	 77071	Cola	<b>01</b>				

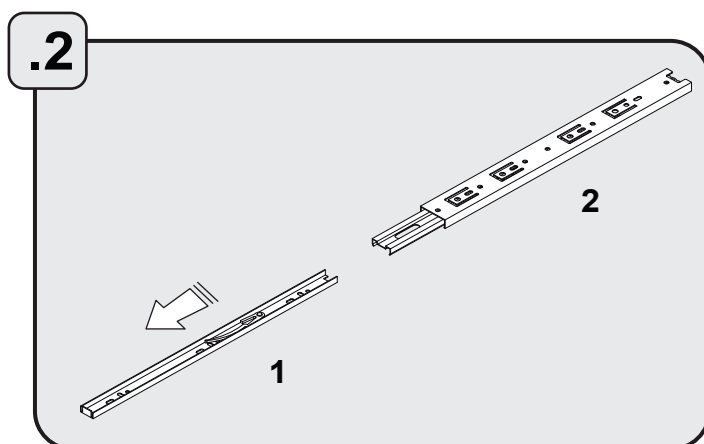
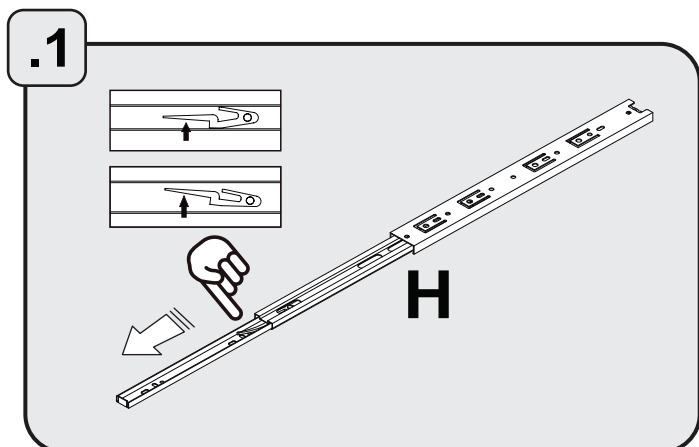

## FERRAMENTAS NECESSÁRIAS HERRAMIENTAS NECESARIAS REQUIRED TOOLS



optional /  
opcional



1.1

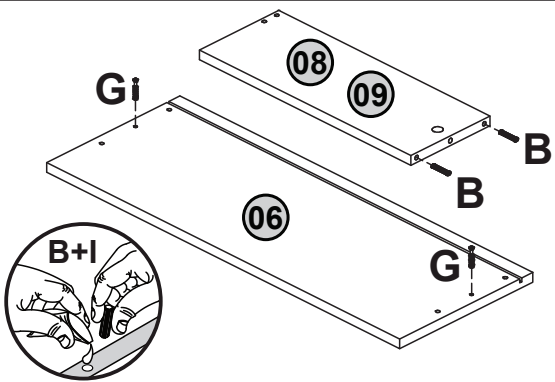

1.2

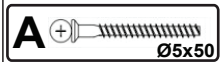
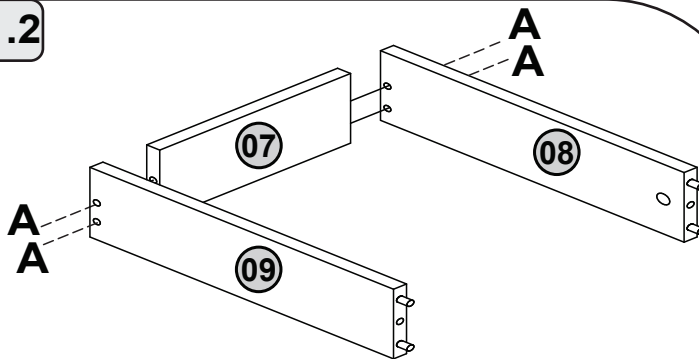

1.3

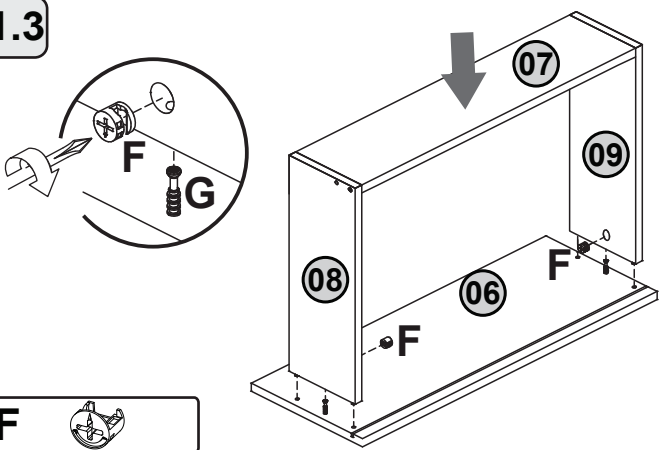

1.4

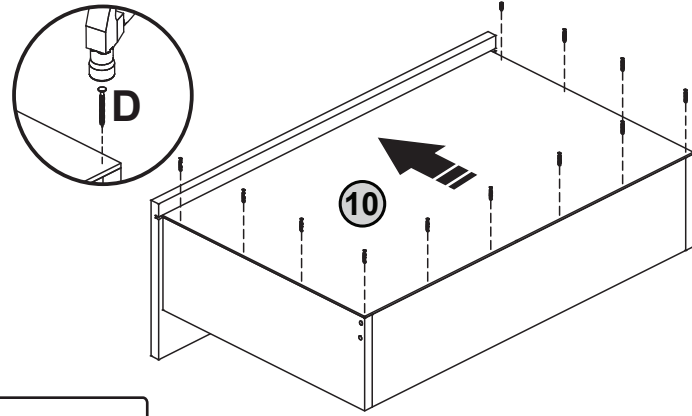

1.5

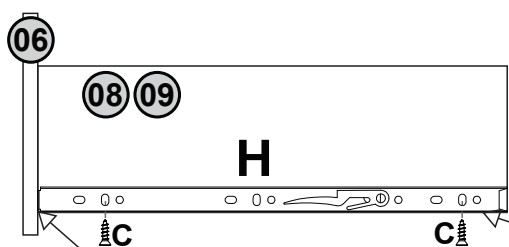

-Alinhar à frente de gaveta  
-Alinear con el frente del cajón  
-Align to drawer front

-Alinhar à parte inferior da gaveta  
-Align the bottom of the drawer  
-Alinee la parte inferior del cajón.

2

